



**INTERNATIONAL ADVANCED RESEARCH CENTRE FOR POWDER  
METALLURGY AND NEW MATERIALS (ARCI),**

Balapur P.O, R.R. District, Hyderabad – 500 005, Telangana, India

Tel: 040-244523326, Fax: 040-24442699

Web Site: [www.arci.res.in](http://www.arci.res.in), eMail: stores@arci.res.in

**Tender No. SC20220021/PO**

**Date: 26.07.2022**

**TENDER DOCUMENT**

**FABRICATION OF SHRINK FIT COMPOUND HOT EXTRUSION  
DIE CONTAINER AS PER DRAWING**

1.	EMD ( Earnest Money Deposit/Bid Security)	<b>INR 6800/-</b>
2.	Tender Processing Fee	<b>INR 590/- (INR 500+18%GST)</b>
3.	Tender document published date	<b>26.07.2022</b>
4.	Bid documents can be downloaded from	<a href="http://www.arci.res.in">www.arci.res.in</a> <a href="https://eprocure.gov.in/epublish/app">https://eprocure.gov.in/epublish/app</a>
5.	Clarification start date and end date	<b>26.07.2022 to 28.07.2022</b>
6.	Bid submission start date and time	<b>29.07.2022 At 09.00AM</b>
7.	Bid submission end date and time	<b>17.08.2022 up to 03.30 PM</b>
8.	Bids opening date and time (for <b>Cover-1 Tender Fee and EMD and Cover 2 Technical Bid</b> )	<b>18.08.2022 at 02.00 PM</b>



# INTERNATIONAL ADVANCED RESEARCH CENTRE FOR POWDER METALLURGY AND NEW MATERIALS (ARCI)

Balapur P.O, R.R. District, Hyderabad – 500 005, Telangana, India

Tel: 040-24452326, Fax: 040-24442699

Web Site: [www.arci.res.in](http://www.arci.res.in) eMail: stores@arci.res.in

## Instructions to Bidder

### Table of Contents

Sl. No.	Description	Page No.
1.	Notice inviting Tender	03-05
2.	Technical Bid -Terms and conditions	06-09
3.	Tender Fee and Earnest Money Deposit-Terms and Conditions	10-11
4.	Price Bid	12-13
5.	Vendor Declaration	14
6.	Scope of the Supply (Technical specifications) (Annexure-I)	15
7.	Technical Compliance statement(Annexure-II)	16
8.	Price Schedule (Annexure-III)	17
9.	Checklist	18
10.	Drawing Sheet	19



# INTERNATIONAL ADVANCED RESEARCH CENTRE FOR POWDER METALLURGY AND NEW MATERIALS (ARCI),

Balapur P.O, R.R. District, Hyderabad – 500 005, Telangana, India

Tel: 040-24452326, Fax: 040-24442699

Web Site: [www.arci.res.in](http://www.arci.res.in) eMail: stores@arci.res.in

---

## **TENDER NOTICE**

International Advanced Research Centre for Powder Metallurgy and New Materials (ARCI) is an Autonomous Research and Development Centre of Department of Science and Technology (DST), Government of India with main campus at Hyderabad and with operations in Chennai and Gurgaon.

ARCI would like to procure the following equipment. The Technical Specifications Schedule of Requirements and Allied Technical details are given in Part-1 of tender document.

**ITEM: Fabrication of Shrink Fit Compound Hot Extrusion Die Container as per drawing.**

Tender Enquiry No: (Case No.) **SC20220021/PO dated. 26.07.2022**

- Last date and time of submission of Tender (Tender Fee, EMD, Technical and Price Bid): **17.08.2022** before 3:30 PM.
- The item to be delivered and installed at:

**International Advanced Research Centre for Powder Metallurgy and New Materials, Balapur Post, Hyderabad – 500 005, Telangana, India.**

- **Estimated Delivery period: 02 months from the date of P.O.**

### **The tender document should consist of the following:**

Two bid system should be followed for this tender. In this system the bidder must submit offer in three separate sealed envelopes i.e., one envelope for each for Tender Fee and EMD, Technical Bid and Commercial Bid. These envelopes should be securely sealed and stamped separately and clearly marked as “**Envelope No.1- TENDER FEE and EMD**”, “**Envelope No. 2- Technical Bid**” and “**Envelope No.3 – Commercial Bid**”. All the sealed envelopes should be placed in another larger envelope. The main envelope which will contain all the envelopes should be super-scribed with the tender enquiry no. **SC20220021/PO** date **26.07.2022** due on **17.08.2022** with name of the equipment /item and is to be submitted to the address given below so as to reach **on or before 17.08.2022 by 03:30 PM.**

*The Bidder should ensure that the Prices are mentioned only in the Financial Bid and nowhere in the Technical Bid.*

### **Validity of Bid**

Quotation should have minimum validity of **90 days** from the date of opening.

### **Address for submission of the Tender:**

**International Advanced Research Centre for Powder Metallurgy and New Materials, Balapur Post, Hyderabad – 500 005, Telangana, India.**

**Last date for submission: 17.08.at 1530hrs.**

Tender should be submitted before last date stated above. The bid can be submitted in person or through post/courier. ARCI will not be responsible for transit delay for tenders submitted by Post / Courier etc.

**All the tenders, in which any of the prescribed conditions are not fulfilled or incomplete in any respect are liable to be rejected.**

**“Only Indigenous bidders are allowed to participate in this tender”.**

**It may further be noted that the bidders offering imported products will fall under the category of Non-local suppliers.**

**(O.M no. P-45021/102/2019-BE-II-Part (1) (E-50310), DPIIT, dated 4th March, 2021, Ministry of Commerce and Industry)**

**Bidders those who are interested to participate in this tender may follow the guidelines issued by Department for Promotion of Industry and Internal Trade, Public Procurement Section, Govt. of India.**

**(O.M No. P-45021/2/2017-PP (BE-II) Government of India, DPIIT, Ministry of Commerce and Industry, dtd 04.06.2020)**

A Techno Commercial team from buyer organization will visit the facility & verify the declaration particulars.

**Clarification on bid**

Bidders can seek clarification as per the schedule start and end date through email IDs given below:

For technical clarifications: [sssarma@arci.res.in](mailto:sssarma@arci.res.in).

For commercial clarifications: [stores@arci.res.in](mailto:stores@arci.res.in).

“NO REQUEST FOR CLARIFICATION OR QUERY SHALL BE NORMALLY ENTERTAINED AFTER THE CLARIFICATIONS END DATE” Should ARCI deem it necessary to amend the bidding documents as a result of a clarification, it shall do so by hosting the clarifications and amendments on the website of ARCI/PPP Portal only for the benefit of other prospective bidders. Hence, prospective bidders are requested to follow the websites regularly.

**Opening of the tender**

The offer/bid will be opened by a committee duly constituted for this purpose. The bidder if interested may participate on the tender opening date and time. The bidder should produce authorization letter from their company to participate in the tender opening. Only one representative will be allowed to participate in the tender opening. The schedule of tender opening is:

**Cover 1 Tender Fee and EMD and Cover 2 Technical Bid opening date and Time: 18.07.2022 at 02.00 PM**

**PLACE: - International Advanced Research Centre for Powder Metallurgy and New Materials, Balapur Post, Hyderabad – 500 005, Telangana, India.**

**The bidders who are technically qualified will be called separately for opening of price bids.**

## **Award of Contract**

Contract will be awarded to successful bidder and a copy of the award of the contract will be uploaded in CPP portal after finalizing the tender.

## **Disqualification of the Tenders:**

The tenders are liable for rejection in the following circumstances:

- If they are not in line with the terms and conditions of this tender notice.
- Conditional quotations
- Incomplete tenders
- Tenders without Tender Fee and EMD.
- Tenders submitted through Fax or e-mail.
- If two bid system is not followed.
- Bid received simultaneously from Indian agent on behalf of Principal/OEM and Principal/OEM itself for same item/product/services in the same tender.
- The Firm need to quote all the charges /prices as per the tender requirement, if any firm quote nil charges/consideration, the bid shall be treated as Unresponsive bid and will not be considered.

Director, ARCI reserves the right to accept or reject any or all tenders either in part or in full or to split the order without assigning any reasons there for.

**IMPORTANT NOTE: Amendment, Corrigendum if any to this tender document, WILL BE HOSTED ONLY IN ARCI WEBSITE and CPP Portal and no separate Press Notification will be issued. Bidders are advised to visit our website and CPP Portal regularly to know such details.**

**Director, ARCI, Hyderabad**

## PART-1

### TECHNICAL BID (Terms and Conditions)

#### **I. Vendor qualification criteria:**

- A. Original Equipment Manufacturer (OEM) or authorized representatives of OEM only can quote for this tender. Vendor should submit authorization letter valid on tender date from OEM along with the quotation.
- B. The OEM should have proven expertise in manufacture and supply of the item.
- C. The bidder should have supplied at least 05 or more similar units in India.
- D. It is essential that the manufacturer shall provide the list of users of the equipment with contact particulars.
- E. OEM is required to submit a letter of commitment at the time of quote for supply of spares and also for efficient and prompt after sales service of the equipment for a minimum period of 5 years after the guarantee/warranty period under mutually agreed terms and conditions.
- F. Failure to meet any of the above vendor qualification criteria may lead to disqualification of tender at technical evaluation stage itself and vendor's quotation may not be considered for procurement.

#### **II. Pre dispatch inspection**

- A. The manufacturer/supplier of the unit shall demonstrate, if required, at their works during pre-dispatch inspection by ARCI personnel and shall satisfy all the technical specifications as described in the tender document.
- B. The manufacturer /supplier of the unit shall demonstrate the features as provided in **Annexure-I (Scope of supply work)**.
- C. All the consumables, raw materials, required for the above demonstration should be arranged by the tenderer.
- D. All the utilities and manpower required for the demonstration shall be arranged by the supplier only

#### **III. Acceptance criteria:**

- A. The manufacturer/supplier's trained engineer should carry out installation and commissioning of the unit at ARCI.
- B. The entire functionality of the equipment according to the specifications should be demonstrated at ARCI.
- C. The manufacturer/supplier of the unit shall demonstrate the features as specified in **Annexure I (Scope of work)**.
- D. Infrastructure required for the above demo will be arranged by ARCI.
- E. The manufacturer/supplier should comply with the Safety and Compliance Standards as specified in **Annexure I (Scope of Work)**.

#### **IV. Other aspects:**

##### **1. PATENT RIGHTS:**

The Supplier shall indemnify ARCI against all third-party claims of infringement of patent, trademark or industrial design rights, copy rights arising from use of the Goods or any part thereof in India.

##### **2. Training:**

The manufacturer shall impart training in the operation and preventive/breakdown maintenance of the complete unit including sub-parts during installation to ARCI personnel for at least 5 no. of days at ARCI.

##### **3. Utilities/Infrastructure for installation:**

A. Supplier shall indicate all the required utilities/infrastructure such as power, water, gas, etc including power backup requirements.

B. Supplier shall provide overall dimensions of the Unit along with floor area/height of the site or building, including foundation details if any, for accommodating the Unit.

C. The operating environment for the Unit including temperature and humidity control, anti-vibration, EMI, EMC etc. should be indicated.

D. If any charges extra are payable for Installation and Commissioning, the same should be included in the total cost of the stores as per the price schedule.

##### **4. Manuals, software and other drawings etc.:**

The following documents (in English) shall be provided along with the Unit in both hardcopy and softcopy forms:

- A. Operation and maintenance manuals, troubleshooting procedures, calibration methods, wiring and other schematic diagrams, list of components, spares and accessories.
- B. If there are any bought-out systems and components, manuals should be provided in hardcopy and softcopy forms for the same.
- C. Calibration certificates for sensors, instruments, gauges, display units etc. must be provided.
- D. Software upgrades pertaining to the supplied Unit should be provided free of cost as and when new versions are released by the OEM.
- E. Safety and security instruction manual should be provided.

##### **5. After-sales service:**

The supplier shall guarantee efficient and prompt after-sales service including the supply of the spares for a minimum period of 5 years after the guarantee/warranty period under mutually agreed terms and conditions.

##### **6. Bought-out items:**

All bought-out sub-systems and components if any should be of reputed make conforming to international standards. Make and details of all bought-out sub-systems and components shall be specified.

## **7. General Quote:**

The breakup for accessories or sub system(s) /attachments apart from the basic system, if any, should be quoted separately.

## **8. Technical compliance statement:**

**The vendor should provide item wise details against each and every specification. Deviations if any are to be highlighted. Suppliers are required to provide the Technical Compliance Statement as per Annexure – II while submitting the Technical Bid (Cover 2).**

## **09. Guarantee/warranty:**

The Unit shall be under warranty **for a period of three years from the date of acceptance**. During the warranty period, all software and hardware updates shall be provided free of cost. Items, if any, excluded from the warranty shall be explicitly mentioned by the supplier.

The Unit shall be guaranteed for satisfactory performance for 3 years from the date of installation, commissioning and acceptance at ARCI. The manufacturer shall replace premature failure of parts during the guarantee period at their cost and risk.

## **10. Delivery/ time schedule:**

The offer shall be accompanied by a detailed delivery time schedule showing the individual time schedule required for delivery.

## **11. Packing:**

The Supplier shall provide such packing of the Goods as is required to prevent their damage or deterioration during transit to their final destination. The packing shall be sufficient to withstand, without limitation, rough handling during transit and exposure to extreme temperatures, salt and precipitation during transit and open storage. Packing case size and weights shall take into consideration, where appropriate, the remoteness of the Goods' final destination and the absence of heavy handling facilities at all points in transit. In order to maintain safety of the equipment, we prefer to have wooden crating with adequate cushion inside for transportation of any goods. The material has to be dispatched with International standard packing to withstand rigors, and to avoid any transit damages.

## **12. Insurance:**

The Goods supplied under the Contract shall be fully insured in Indian Rupees against loss or damage incidental to manufacture or acquisition, transportation, storage and delivery.

For delivery of goods at the purchaser's premises, the insurance shall be obtained by the Supplier in an amount equal to 110% of the value of the goods from "Warehouse to warehouse" (final destinations) on "All Risks" basis including War Risks and Strikes. The insurance shall be valid for a period of not less than 3 months after dispatch **or upto installation and commissioning of stores whichever is later. The supplier shall arrange Insurance F.O.R, ARCI Hyderabad.**



### 13. General instructions:

- A. The Technical Bid must be submitted in an organized and structured manner. No brochures/leaflets etc. should be submitted in loose form. Please indicate page nos. on your quotation. **The price should not be mentioned anywhere in this document.**
- B. Tenders, which are submitted without following the Two-Bid Offer System, are liable to be rejected.
- C. The technical offer should be complete to indicate that all products and services asked for are quoted. Each page of the bid and cutting/corrections shall be duly signed and stamped by the bidder. Unsigned Tenders are liable to be rejected. Failure to comply with this requirement may result in the bid being rejected.
- D. The purpose of certain specific conditions is to get or procure best product/service etc. for ARCI. The opinion of Technical Committee shall be the guiding factor for technical short listing.
- E. Vendor should provide list of deliverables / bill of materials and services.

## PART- 2

### TENDER FEE AND EARNEST MONEY DEPOSIT/BID SECURITY

1. Bid should be accompanied by Tender Processing Fee of INR 500+18%(INR 590/-) GST in the form of Demand Draft drawn on in favour of Director, International Advanced Research Centre, Payable at Hyderabad or payment online like RTGS/NEFT/ECS. Tender Fee is not refundable. Bids submitted without tender processing fee will not be considered for further processing.

2. Bid should be accompanied by EMD INR 6800/- from Indian bidders in the form of Demand Draft or Insurance Surety Bonds or Banker's Cheque or Fixed Deposit Receipt lien registered or Bank Guarantee from any of the Commercial banks in favour of Director, International Advanced Research Centre, Payable at Hyderabad or payment online like RTGS/NEFT/ECS.

The details of transaction for tender fee and EMD viz Name of Bidder firm, tender description, Transaction ID/No. of Transfer, Transaction date, Amount of Transaction, Name of Bank, Address of Bank shall be furnished by the TENDERER ON THEIR LETTERHEAD SEPARATELY ENCLOSED IN COVER-I ALONG WITH TENDER.

Online Payment Account details are as follows:

#### **Details of Account Holder**

Name of the Institution	International Advanced Research Centre for Powder Metallurgy & New Materials
Name of Account Holder (As per Bank Record)	ARCI TECHNOLOGY PROGRAM FUND
Account Number of above account	1849101016974
Complete Contact Address	RCI Road, Balapur, Opposite Balapur Vilage, Hyderabad -500005
Telephone No	0091-040-24452361
Fax No	0091-040-24442699

#### **Bank Account Details**

Bank Name	CANARA BANK
Branch Name	Kanchanbagh
Beneficiary's Name	ARCI Technology Program Fund
Complete Contact Address	Kanchanbagh, Hyderabad 5000059
Telephone No	040-23438704
9- Digit Code No of Bank & Branch	500015032
Account Number	1849101016974
Account Type (SB/Current/Cash/Credit/Etc	Savings Account
IFSC Code No of Bank	CNRB0001849
PAN Number	AAA AI0324C
TIN Number	36980207289
Service Tax Number	AAA AI0324CST001
GSTIN Number	36AAA AI0324C1ZG
E.Mail	<a href="mailto:fao@arci.res.in">fao@arci.res.in</a>

3. No interest is payable on EMD.

4. The EMD shall be valid for a minimum period of three months from the date of closure of the bid.

5. Bidder registered with District Industries Centre or Khadi and Village Industries commission or Khadi and Village Industries Board or Coir Board or National Small Industries Corporation (NSIC) or Directorate of Handicrafts and Handloom or Udyog Aadhar Memorandum or any other body specified by Ministry of Micro, Small and Medium Enterprises as MSMES or Startups as recognized by Department of Industrial Policy and Promotion (DIPP), Govt of India for the tendered item are exempted from payment of tender fee and Earnest Money Deposit (EMD) subject to submission of valid documentary evidences throughout the time of the contract. Copies of MSME, NSIC registration certificates and other supporting documents should be submitted both online and offline. Failure to submit the required documents in cover 1 in both online and offline shall lead to rejection of bid.

**Refund of EMD:**

Bid securities of the unsuccessful bidders should be returned to them at the earliest after expiry of the final bid validity and latest on or before the 30th day after the award of the contract. However, in case of two packet or two stage bidding, bid securities of unsuccessful bidders during first stage i.e., technical evaluation etc should be returned within 30 days of declaration of results of first stage i.e., technical evaluation etc.

**Forfeiture of EMD:**

EMD of tenderer will be forfeited, if the tenderer withdraws or amends its tender or derogates from the tender in any respect within the period of validity of its tender. Further, if the successful tenderer fails to furnish the required performance security within the specified period, its EMD will be forfeited.

## **PART-3**

### **PRICE BID**

#### **I. Terms and Conditions:**

- a) Envelope 3 should contain price schedule (as per the table) complete in all respects with proper seal and signature of authorized person.
- b) Tender with any condition, including conditional rebate, are liable to be rejected.
- c) Cost of all the items should be mentioned clearly and individually in the Commercial Offer (Part- III) only.
- d) AMC scope with associated costs including number of visits has to be quoted separately.
- e) The Bidders are requested to quote for **research institutional prices** for Machine/ Equipment and, since ARCI is eligible for the same. The quoting party should ensure that the quoted prices are the minimum and that have not quoted the same item on lesser rates than those being offered to ARCI to any other customer.
- f) Printed conditions of the vendor submitted with the tender will not be binding on ARCI.
- g) The commercial bids of only the technically qualified bidders shall be considered for further processing.
- h) Price quoted should be FOR (destination) price which should include packing, freight and insurance, if any. Cost of Installation and commissioning if extra, may be quoted separately.
- i) Commercial Bid (prices quoted) should not be enclosed in the technical bid envelope. If the price quote is submitted with technical bid the tender are liable to be rejected.
- j) The Director ARCI reserves the right to accept the offer in full or in parts or reject summarily or partly thereof.

#### **II. Payment terms:**

Subject to deduction of taxes at source, if any,

97% of the goods cost + 100% taxes will be paid after receipt of the goods at our site subject to inspection & acceptance of the goods/works/commissioning by ARCI authorities.

Balance 3% will be paid against submission of Performance Bank Guarantee (i.e. 3% of the total order value excluding taxes etc.) from a Nationalized /Scheduled Bank valid till the expiry of the warranty period OR after completion of warranty period from the date of successful commissioning of equipment at ARCI.

#### **III. Final Acceptance Certificate (FAC):**

On installation, the working of the equipment should be demonstrated so as to comply with all the technical specifications. In this connection, it is to be noted that the installation report is not to be treated as the Final acceptance certificate (FAC)

The FAC will be issued by the PURCHASER only on demonstration of the technical specifications. The warranty shall commence only from the date of the issuance of the FAC. The FAC shall be issued by the PURCHASER at a date not later than 30 (thirty) days from the date of installation provided the equipment functions as per the specifications.

#### **IV. Liquidated Damages (LD):**

As time is the essence of the contract, delivery period mentioned in the Purchase Order should be strictly adhered to. Otherwise, LD clause will be applicable /enforced. If the supplier fails to Supply, Install and Commission the equipment as per specifications mentioned in the order within the due date, ARCI may levy a penalty for such delay by way of liquidated damages, at 0.5% per week of delay or part thereof, and in aggregate not exceeding 10% of the order value. Such LD will be deducted from any amount due or which may become due to the supplier.

## **V. Order acceptance:**

The successful bidder, on award of contract / order, must send the contract / order acceptance in writing, within 15 days of award of contract / order failing which the EMD will be forfeited.

## **VI. Award of contract:**

ARCI reserves the right at the time of award of Contract to increase or decrease the quantity of items specified in the Schedule of Requirements without any change in price or other terms and conditions.

## **VII. Corrupt or Fraudulent Practices:**

ARCI requires that the bidders who wish to bid for this project have highest standards of ethics. ARCI will reject a bid if it determines that the Bidder recommended for award has engaged in corrupt or fraudulent practices while competing for this contract. ARCI may declare a vendor ineligible, either indefinitely or for a stated duration, to be awarded a contract if it at any time determines that the vendor has engaged in corrupt and fraudulent practices during the execution of contract.

## **VIII. Interpretation of the clauses in the Tender Document / Contract Document:**

In case of any ambiguity / dispute in the interpretation of any of the clauses in this Tender Document, Director, ARCI's interpretation of the clauses shall be final and binding on all parties.

The equipment must be supported by service personnel trained by the principal vendors. The vendor will have to arrange for all the testing equipment & tools required for installation, testing & maintenance etc. Installation and integration of all supplied hardware and software shall be done by the vendor. The vendor shall install and configure all required hardware and software. The bidder must install and configure user application / software, and demonstrate its running in parallel as part of the system acceptance. The application software will be provided by the Institute.

## **IX. Indemnity:**

The vendor shall indemnify, protect and save ARCI against all claims, losses, costs, damages, expenses, action suits and other proceeding, resulting from infringement of any law pertaining to patent, trademarks, copyrights etc. or such other statutory infringements in respect of all the equipment's supplied by him.

## **X. Arbitration**

In case of Dispute or difference arising between the Purchaser and a supplier relating to any matter arising out of or connected with this agreement, such disputes or difference shall be settled in accordance with the Indian Arbitration & Conciliation Act, 1996, the rules there under and any statutory modifications or re-enactments thereof shall apply to the arbitration proceedings. The dispute shall be referred to arbitrator appointed by Director ARCI. The award of the arbitrator so appointed shall be final, conclusive and binding on all parties to this order.

The venue of the arbitration shall be the place from where the purchase order/contract is issued.

Notwithstanding any reference to arbitration herein, the parties shall continue to perform their respective obligations under the Contract unless they otherwise agree.

## **Declaration by the Vendor**

It is hereby declared that I/We the undersigned, have read and examined all the terms and conditions etc. of the tender document for which I/We have signed and submitted the tender under proper authorization. It is also certified that all the terms and conditions of the tender document are fully acceptable to me/us and I/We will abide by the conditions of the tender. We have not given any printed conditions beyond the scope of this tender. This is also certified that I/We/our principal manufacturing firm has no objection in signing the purchase contract if the opportunity for the supply of the items against this tender is given to me/us.

Date:

Signature:

Name:

Address:

Designation:

On behalf of:

**SCOPE OF SUPPLY**

**FABRICATION OF SHRINK FIT COMPOUND HOT EXTRUSION DIE CONTAINER AS PER DRAWING**

Part has to be fabricates as per the attached drawing.

Cylinder/part, 1 indicated in the drawing:

ID: 50 mm OD taper dia sizes: 116.039/130mm

Cylinder/part 2:

ID taper dia sizes: 116.039/130 mm

OD taper dia sizes: 236/250 mm

Cylinder/part 3:

ID taper dia sizes: 236/250 mm

All dimensions as per the attached drawing.

**Eligibility criteria: Supplied should have supplied at least one die container to the reputed organization. The supplied Die container should be a compound die container with three cylinders shrink fitted coaxially for hot extrusion of steel billets of minimum 50 mm size, extruded at 1100 MPa load and container temperature of 300 C. Previous Supplier order for the above eligibility criteria is required.**

**Supply, installation, commissioning, training and services must be done at**

**International Advanced Research Centre for Powder Metallurgy and New Materials,  
Balapur Post, Hyderabad – 500 005, Telangana, India**

-----

**ANNEXURE –II**  
**TECHNICAL COMPLIANCE STATEMENT**

<b>Sr No</b>	<b>Item Description</b>	<b>Technically compliance as per specification given (Yes/No)</b>	<b>Remarks / Deviations (if any)</b>

**Suppliers are required to provide this Technical Compliance Statement while submitting the Technical Bid (Cover 2).**



## ANNEXURE-III

### **PRICE SCHEDULE FOR SUPPLY OF GOODS / SERVICES**

Sl No	ARCI item code	Name of the Goods / Services / Works	HSN / SAC codes	UoM	Quantity	Unit Price	Discount	CGST	SGST	IGST	Total Tax amount	Total amount (including tax)
<b>Amount in Words:</b> <b>(FOR ARCI Hyderabad)</b>												

*Note: The Bidder may please fill in this form or the same may be typewritten on the Letter Head of the Bidder exactly as per the above format and submit the same as per the instructions given in the tender document.*

**Note:**

1. ARCI is a public funded research institution; concessional GST rate @ 5% may please be quoted for the supply of goods with reference to GST Notification no. 45/2017 dated 14.11.2017 ARCI will provide certificate for the same.
2. **Price quoted should be FOR (destination) price which should include packing, freight and insurance, if any. Cost of Installation and commissioning if extra, may be quoted separately.**

**Other Information:**

1. Installation and commission charges, if any to be added as a line item in the format given above.
2. Prices of accessories, spares and consumables must be added as a line item as per the format given above.
3. Optional items, if any, and their prices with applicable taxes and HSN/SAC codes should be mentioned separately

**[SIGNATURE OF BIDDER]**  
**NAME AND ADDRESS OF BIDDER**

---

## CHECK LIST

### BIDDER HAS TO FILL IN THE CHECK LIST GIVEN BELOW

(State YES/NO for each item)

1	If bidder is not an original equipment manufacturer, authorization letter attached.	
2.	Whether Tender Fee and Earnest Money Deposit (EMD) Submitted (envelope I)	
3.	Whether Technical Bid (envelope II) Submitted	
4.	Whether Commercial Bid (envelope III) Submitted	
5.	Whether the Tender Fee and EMD (envelope I), Technical Bid (envelope II) and Price Bid (envelope III) are submitted in separate covers and all the covers enclosed in a common envelope.	
6.	Whether copies of GST Registration certificate and PAN Card enclosed	
7.	Whether declaration form signed and submitted	
8.	Validity of 90 days from the date of opening	
9.	Whether warranty clause mentioned	
10.	Does the instrument comply with all the specifications mentioned	
11.	Whether all pages of tender document signed and submitted	
12.	Payment terms	

**NOTE:** Please ensure all the relevant boxes are marked YES/NO against each column.

**IMPORTANT NOTE:** Tenderers must ensure that all the required documents indicated in the Tender documents are submitted without fail. Tenders received without supporting documents for the various requirements mentioned in the tender document are liable to be rejected at the initial stage itself.

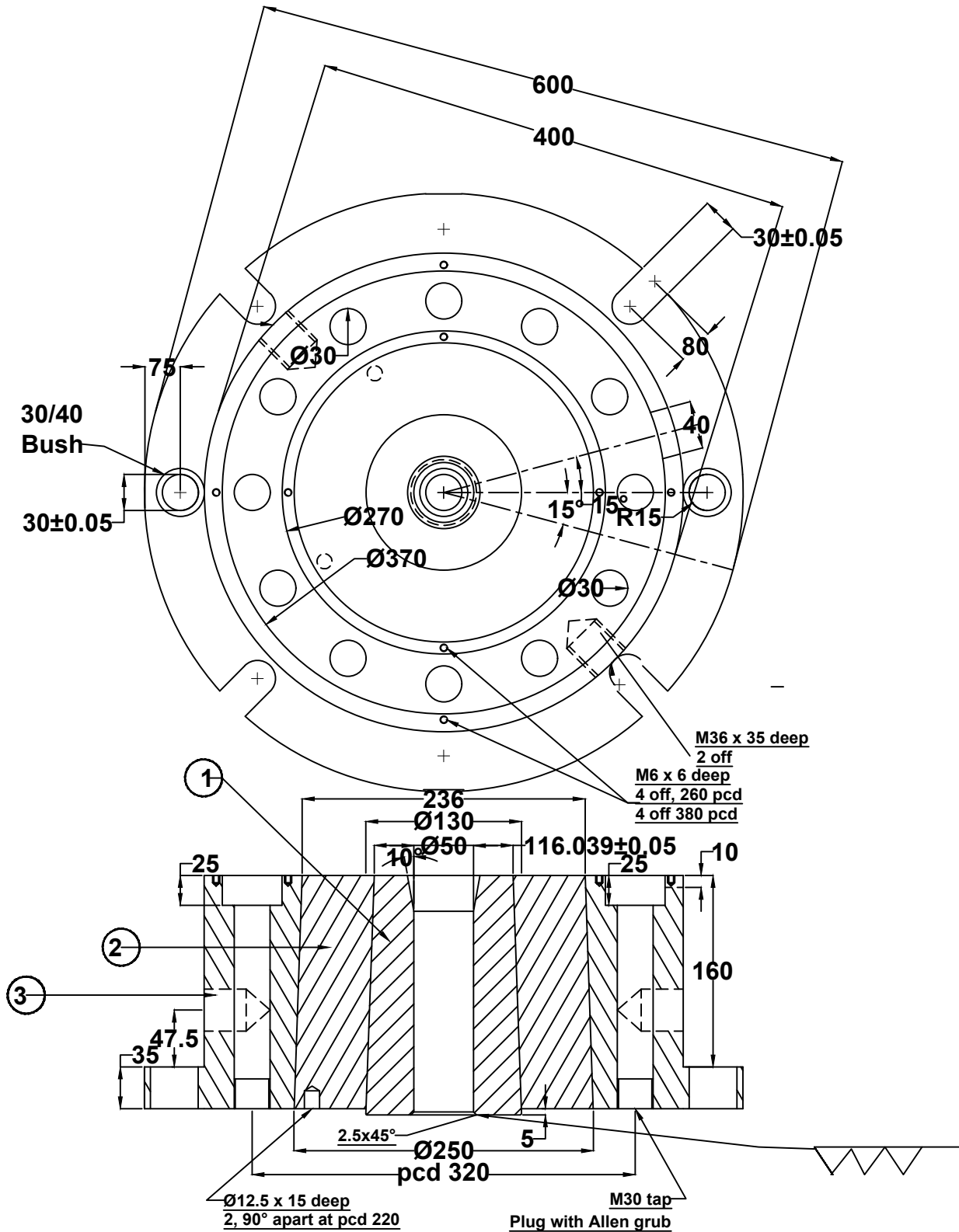

### Part 8

1. Material: Part 1:H21, Part 2: H11, Part 3: EN8
2. Fit: Interference fit of Parts 1, 2 & 3. Means Between 1 & 2,2&3.