



**INTERNATIONAL ADVANCED RESEARCH CENTRE FOR
POWDER METALLURGY AND NEW MATERIALS (ARCI)**

Balapur P.O, R.R. District, Hyderabad – 500 005, Telangana, India

Tel: 040-24452326, Fax: 040-24442699

Web Site: www.arci.res.in eMail: stores@arci.res.in

Tender No. SC20190182/PO

Date: 11.11.2019

e-TENDER DOCUMENT

**PROCUREMENT, INSTALLATION AND COMMISSIONING
OF ELECTRON BEAM MELTING FACILITY**

1.	EMD (Earnest Money Deposit/Bid Security)	Rs 16,25,000/-
2.	Tender Processing Fee	Nil
3.	e-Tender document published date	11.11.2019
4.	Bid documents can be accessed from	https://eprocure.gov.in/eprocure/app
5.	Clarification start date and end date	12.11.2019 to 21.11.2019
6.	Bid submission start date and time	25.11.2019 at IST 09:00 hrs.
7.	Bid submission end date and time	24.12.2019 before IST 15:30 hrs.
8.	Online Bids opening date and time (for Technical Bids)	26.12.2019 at IST 12:00 hrs.



INTERNATIONAL ADVANCED RESEARCH CENTRE FOR POWDER METALLURGY AND NEW MATERIALS (ARCI)

Balapur P.O, R.R. District, Hyderabad – 500 005, Telangana, India

Tel: 040-24452326, Fax: 040-24442699

Web Site: www.arci.res.in eMail: stores@arci.res.in

Instructions to Bidders

Table of Contents

Sl. No.	Description	Page No.
1.	Notice for inviting e-tender	3-5
2.	Special Instructions for online bid submission	6-8
3.	Part – 1: Technical Bid -Terms and conditions	9-15
4.	Part – 2: Earnest Money Deposit-Terms and Conditions	16-17
5.	Part – 3: Price Bid -Terms and Conditions	18-21
6.	Declaration by Vendor	22
7.	Scope of Supply (Annexure – I)	23-28
8.	Drawing for proposed equipment/supply (Annexure – II)	29
8.	Technical Compliance Statement (Annexure III)	30-33
9.	Format for Integrity Pact (Annexure – IV)	34-36
10.	Checklist	37



INTERNATIONAL ADVANCED RESEARCH CENTRE FOR POWDER METALLURGY AND NEW MATERIALS (ARCI)

Balapur P.O, R.R. District, Hyderabad – 500 005, Telangana, India

Tel: 040-24452326, Fax: 040-24442699

Web Site: www.arci.res.in eMail: stores@arci.res.in

NOTICE FOR INVITING OPEN E-TENDER

International Advanced Research Centre for Powder Metallurgy and New Materials (henceforth referred to as ARCI) is an Autonomous Research and Development Centre of Department of Science and Technology (DST), Government of India with main campus at Hyderabad and with operations in Chennai and Gurugram.

ARCI would like to procure the following equipment. The Technical Specifications, Schedule of Requirements and Allied Technical details are given in Part-1 of tender document.

SERVICE: PROCUREMENT, INSTALLATION AND COMMISSIONING OF ELECTRON BEAM MELTING FACILITY

You are invited to submit your most competitive online quotation through CPP Portal (Central Public Procurement Portal) website <https://eprocure.gov.in> on or before the prescribed due date. Manual bids shall not be accepted except for the original documents, if any mentioned in this tender.

Complete tender can be viewed and submitted through <https://eprocure.gov.in/eprocure/app>. To use the Electronic tender portal <https://eprocure.gov.in/eprocure/app> the bidders need to register on the portal.

Tender Enquiry No: (Case No.) SC20190182/PO date 11.11.2019

- Last date and time of submission of Tender online (EMD, Technical Bid, and Price Bid): **24.12.2019 before 15:30 hrs.**
- EMD should be in the form of Demand Draft drawn in favour of **Director, International Advanced Research Centre, payable at Hyderabad.**
- Services to be provided at:

International Advanced Research Centre for Powder Metallurgy and New Materials, Balapur Post, Hyderabad – 500 005, Telangana, India.

- **Estimated value: INR 6,50,00,000/-**
- **Estimated Delivery period: 03 (Three) Months from the date of Purchase Order.**

Validity of Bid

Quotation should have minimum validity of **120 days** from the date of opening

Last date for submission: 24.12.2019 before 15:30 hrs.

The bidders are required to submit soft copies of their bids electronically on the CPP Portal before the last date stated above using valid Digital Signature Certificates.

All the tenders, in which any of the prescribed conditions are not fulfilled or incomplete in any respect are liable to be rejected.

Bidders shall select the payment option as offline to pay the EMD and enter details of the Demand Draft, etc

Clarification on bid

Bidders can seek clarification as per the schedule start and end date through email IDs given below:

For technical clarifications: **manish@arci.res.in**

For commercial clarifications: **stores@arci.res.in**

Opening of the tender

- Only the Technical bid shall be opened online on the date of the tender opening. Price bids of only those firms will be considered for opening whose offer would meet all tender requirements including compliance to technical specifications and has passed all tender conditions/ technical evaluation.
- After opening of the price bids, detailed comparative statement will be generated online and the finalization of successful bidder will be done on L-1 (lowest price) basis as per CPP Portal.

Award of Contract

Contract will be awarded to successful bidder and a copy of the award of the contract will be uploaded in CPP portal after finalizing the tender.

DISQUALIFICATION OF TENDERS:

The tenders are liable for rejection in the following circumstances:

- If they are not in line with the terms and conditions of this tender notice.
- Conditional quotations
- Incomplete tenders
- Tenders without EMD
- Tenders submitted through Fax or e-mail.
- If two bid system is not followed.
- Bid received simultaneously from Indian agent on behalf of Principal/OEM and Principal/OEM itself for same item/product/services in the same tender.

Director, ARCI reserves the right to accept or reject any or all tenders either in part or in full or to split the order without assigning any reasons there for.

The original hard copies of Technical Bid documents along with EMD, supporting documents, etc., should be submitted on or before the due date to the following address:

International Advanced Research Centre for Powder Metallurgy and New Materials, Balapur Post, Hyderabad – 500 005, Telangana

IMPORTANT NOTE: Amendment, Corrigendum if any to this tender document, WILL BE HOSTED ONLY IN ARCI WEBSITE and CPP Portal and no separate Press Notification will be issued. Bidders are advised to visit our website and CPP Portal regularly to know such details.

Director, ARCI, Hyderabad

SPECIAL INSTRUCTIONS FOR ONLINE BID SUBMISSION:

Instructions to the Bidders to submit the bids online through the Central Public Procurement Portalfore-Procurement are at <https://eprocure.gov.in/eprocure/app>. The bidders must carefully follow the instructions.

- Possession of valid Digital Signature Certificate (DSC) and enrolment/registration of the contractors/bidders on the e-procurement/e-tender portal is a prerequisite for e-tendering.
- Bidder should do the enrolment in the e-Procurement site using the "Click here to Enroll" option available on the home page. Portal enrolment is generally free of charge. During enrolment/registration, the bidders should provide the correct/true information including valid e-mail-id. All the correspondence shall be made directly with the contractors/bidders through e-mail-id provided.
- Bidder need to login to the site through their user ID/ password chosen during enrolment/registration.
- Then the Digital Signature Certificate (Class III Certificates with signing key usage) issued by NIC/SIFY/TCS/nCode/eMudra or any Certifying Authority recognized by CCA India on e-Token / Smart Card, should be registered.
- The DSC that is registered only should be used by the bidder and should ensure safety of the same.
- Contractor / Bidder may go through the tenders published on the site and download the required tender documents/ Annexures for the tenders he/she is interested.
- After downloading / getting the tender document/ Annexures/ Appendices, the Bidder should go through them carefully and then submit the documents as asked, otherwise bid will be rejected.
- If there are any clarifications, this may be obtained online through the tender site, or through the contact details. Bidder should take into account the corrigendum / addendum published before submitting the bids online.
- Bidder then logs in to the site through the secured log in by giving the user id/ password chosen during enrolment/registration and then by giving the password of the e-Token/ Smart Card to access DSC.
- Bidder selects the tender which he/she is interested in by using the search option & then moves it to the 'my tenders' folder.
- From my tender folder, he selects the tender to view all the details indicated.
- It is construed that the bidder has read all the terms and conditions before submitting their offer. Bidder should go through the tender Annexures and appendices carefully and upload the documents as called for; otherwise, the bid will be rejected.
- Bidder, in advance, should get ready the bid documents to be submitted as indicated in the tender document/ Annexure and generally, they can be in PDF/xls/rar/zip/dwf formats. If there is more than one document, they can be clubbed together and can be provided in the requested format. Each document to be uploaded through online for the tenders should be

less than 2 MB. If any document is more than 2MB, it can be reduced through zip/rar and the same can be uploaded, if permitted. Bidders Bid documents may be scanned with 100 dpi with black and white option. However if the file size is less than 1 MB the transaction uploading time will be very fast.

- Bidder should take into account the corrigendum / addendum published from time to time before submitting the online bids.
- The Bidders can update well in advance, the documents such as certificates, annual report details etc., under My Space option and these can be selected as per tender requirements and then send along with bid documents during bid submission. This will facilitate the bid submission process faster by reducing upload time of bids.
- While submitting the bids online, the bidder reads the terms & conditions and accepts the same to proceed further to submit the bid packets.
- Bidder should submit the EMD as specified in the tender. The original should be posted/couriered/given in person to the Tender Inviting Authority, within the bid submission due date & time for the tender. **Scanned copy of the instrument should be uploaded as part of the offer.**
- The bidder has to select the payment option as offline to pay the EMD as applicable and enter details of the instruments
- The details of the DD/BC, physically sent, should tally with the details available in the scanned copy and the data entered during bid submission time. Otherwise submitted bid will not be acceptable.
- The bidder has to digitally sign and upload the required bid documents one by one as indicated. Bidders to note that the very act of using DSC for downloading the bids and uploading their offers shall be deemed to be a confirmation that they have read all sections and pages of the bid document including General conditions of contract without any exception and have understood the entire document and are clear about the requirements of the tender requirements.
- The bidder has to upload the relevant files required as indicated in the covered content. In case of any irrelevant files, the bid will be rejected.
- **If the price bid format is provided in a spread sheet file like BoQ_xxxx.xls, the rates offered should be entered in the allotted space only and uploaded after filling the relevant columns. The Price Bid/ BOQ template must not be modified/replaced by the bidder, else the bid submitted is liable to be rejected for this tender.**
- The bidders are requested to submit the bids through online e-tendering system to the Tender Inviting Authority (TIA) well before the bid submission end date & time (as per Server System Clock). The TIA will not be held responsible for any sort of delay or the difficulties faced during the submission of bids online by the bidders at the eleventh hour.
- After the bid submission (i.e after Clicking "Freeze Bid Submission" in the portal), the acknowledgement number, given by the system should be printed by the bidder and kept as a record of evidence for online submission of bid for the

particular tender and will also act as an entry pass to participate in the bid opening date.

- The time settings fixed in the server side & displayed at the top of the tender site, will be valid for all actions of requesting, bid submission, bid opening etc., in the e-tender system. The bidders should follow this time during bid submission.
- All the data being entered by the bidders would be encrypted using PKI encryption techniques to ensure the secrecy of the data. The data entered will not be viewable by unauthorized persons during bid submission & not be viewable by any one until the time of bid opening.
- Any bid document that is uploaded to the server is subjected to symmetric encryption using a system generated symmetric key. Further this key is subjected to asymmetric encryption using buyers/bid openers public keys. Overall, the uploaded tender documents become readable only after the tender opening by the authorized bid openers. The confidentiality of the bids is maintained since the secured Socket Layer 128 bit encryption technology is used. Data storage encryption of sensitive fields is done.
- The bidder should logout of the tendering system using the normal logout option available at the top right hand corner and not by selecting the (X) exit option in the browser.
- For any queries regarding e-tendering process, the bidders are requested to contact as provided in the tender document. For any further queries, the bidders are asked to contact over phone as mentioned in the CPP website or send an email to - cppp-nic@nic.in.

PART-1
TECHNICAL BID - TERMS AND CONDITIONS

I. Vendor qualification criteria:

- A. Original Equipment Manufacturer (OEM) or authorized representatives of OEM only can quote for this tender. Vendor should submit authorization letter valid on tender date from OEM along with the quotation.
- B. The OEM should have proven expertise in manufacture and supply of the item.
- C. The bidder should have supplied at least 05 (five) systems of similar specifications in the last 03 years in India or worldwide and those systems should be in operation till date.
- D. Bidder has to submit EBM manufactured Ti-6Al-4V alloy (Grade 5) component in as-build condition (**Drawing attached in Annexure II. Bidders may contact manish@arci.res.in for 3D Model**). The sample must be manufactured in their own machine similar to what they are offering. The submitted sample will be used for technical qualification. Sample will be analysed for geometrical accuracies, surface roughness and Oxygen content in the build. The build quality should be equal or better than criteria mentioned in section 1.15 and described below:
 - a. Porosity: 0.2% or lower
 - b. Surface Roughness (in as deposited condition): 35µm or lower
 - c. Geometrical Accuracy: +/- 0.2mm or better
 - d. Oxygen content in the built component must be lower than 0.15%
- E. It is essential that the bidder/OEM should provide support documents to show their at least 05 (five) Customers' list with contact details. Performance certificate of latest of them should also be submitted with technical bid.
- F. OEM is required to submit a letter of commitment at the time of quote for supply of spares, tool, and consumables and also for efficient and prompt after sales service of the equipment for a minimum period of 10 years after the guarantee/warranty period under mutually agreed terms and conditions.
- G. The bidder shall provide the details of Service Centres and also the details of the on-site service support agency preferably with OEM trained engineers including the service personnel details, training and infrastructure to support the spares, maintenance and calibration of the complete system and sub-systems after commissioning, during and after the guarantee/warranty period.
- H. Failure to meet any of the above vendor qualification criteria may lead to disqualification of tender at technical evaluation stage itself and vendor's quotation may not be considered for procurement.
- I. The bidder shall furnish documentary evidence of their financial capability duly certified by their bank or any financial institution of repute for previous 3 years and enclose a certificate of last three-year turnover.

II. Pre dispatch inspection

- A. ARCI selected components have to be built. The sample component must be manufactured in the same machine in presence of ARCI scientists. The generated sample will be used for technical qualification. Sample will be analyzed for geometrical accuracies, surface roughness and Oxygen content in the build. The generated samples will be bench marked against the sample supplied with the technical bid. The sample quality should be on par with the sample submitted with technical bid and criteria mentioned in section 1.15 and 11.1 (Annexure I, Scope of work).
- B. Demonstrate quality of build in entire build area.
- C. The manufacturer/supplier of the unit shall demonstrate, if required, at their works during pre-dispatch inspection by ARCI personnel and shall satisfy all the technical specifications as described in the tender document.
- D. The manufacturer /supplier of the unit shall demonstrate the features as provided in **Annexure-I (Scope of supply work)**.
- E. All the tools, accessories, subsystems, consumables, raw materials, required for the above demonstration should be arranged by the bidder.
- F. All the utilities and manpower required for the demonstration shall be arranged by the supplier only.
- G. Demonstrate functionality and operation of the system and all sub-systems as per specifications.
- H. Certificate of conformance of the system suiting ARCI specification from suppliers quality department need to be produced before dispatch of the system.

III. Acceptance criteria:

- A. The manufacturer/supplier's trained engineer should carry out installation and commissioning of the unit at ARCI.
- B. Installation and commissioning of the machine to be done by the supplier at ARCI and proving out of the machine and demonstration of all the features is to be carried out by the supplier at ARCI.
- C. All the activities mentioned in Pre-dispatched inspection must be repeated during commissioning at ARCI.
- D. ARCI selected components have to be built. The sample component must be manufactured in the same machine in presence of ARCI scientists. The generated

sample will be used for technical qualification. Sample will be analyzed for geometrical accuracies, surface roughness and Oxygen content in the build. The generated samples will be bench marked against the sample supplied with the technical bid. The sample quality should be on par with the sample submitted with technical bid and criteria mentioned in section 1.15 and 11.1 (Annexure I, Scope of work). Also Demonstrate quality of build in entire build area

- E. Demonstrate functionality and operation of the system and all sub-systems as per specifications at ARCI.
- F. The manufacturer/supplier of the unit shall demonstrate the features as specified in **Annexure I (Scope of work)**.
- G. On completion of operational and maintenance training for the entire system and sub-systems.
- H. Safety compliance.
- I. Demonstration of all the safety interlocks as per International safety standard.

IV. Other aspects:

A. Patent Rights:

The Supplier shall indemnify ARCI against all third-party claims of infringement of patent, trademark or industrial design rights, copy rights arising from use of the Goods or any part thereof in India.

B. Training:

- a. The manufacturer shall impart training in the operation and preventive/breakdown maintenance of the complete unit including sub-parts during installation to ARCI personnel for approximately 01 month in total.
- b. Suitable training to enable safe, efficient operation and maintenance of the machine. The training must include:
 - Machine operation, system handling
 - Application development with design and build rules
 - Build optimizations and process knowledge.
 - Detailed software training for basic operation and advance operations
 - Preventive maintenance, detailed maintenance training for unscheduled and specialized maintenance requirements, troubleshooting etc
 - Process development using non-standard powders
 - Handling of post-processing equipment for powder recovery and other accessories

C. Utilities/Infrastructure for installation:

- a. Supplier shall indicate all the required utilities/infrastructure such as power, water, gas, etc including power backup requirements.

- b. Supplier shall provide overall dimensions of the Unit along with floor area/height of the site or building, including foundation details if any, for accommodating the system and sub-systems.
- c. The layout, pre-installation requirements and foundation drawing of the offered machine and all the peripheral equipment should be enclosed with the Technical offer (Cover 2)
- d. The operating environment for the system and sub-systems including temperature and humidity control, anti-vibration, EMI, EMC etc. should be indicated.
- e. If any charges extra are payable for Installation and Commissioning, the same should be included in the total cost of the item as per the price schedule.

D. Manuals, software and other drawings etc.:

The following documents (Hard copy 2 sets and soft copy in CD/Flash drive/HDD) in English Language to be provided to ARCI:

- a. User manual, operation manual and maintenance manual (for mechanical, electrical and electronic hardware circuits) of the entire system and sub-systems.
- b. System administration and maintenance manual- shall cover detailed system configuration and administration with the help of sketches. The safety instructions, maintenance schedule, preventive maintenance schedule with possible errors and troubleshooting to be provided.
- c. Standard operating procedure (SOP), calibration, software manual
- d. Original software licenses for all the software included in the supply without any usages limits and time limits should be provided and backup of the software should also be provided in a CD/DVD/Flash drive.
- e. Software upgrades pertaining to the supplied Unit should be provided free of cost as and when new versions are released by the OEM.
- f. Calibration certificates as per international standard of all the artifacts. Reference standard used for the same shall be provided to ARCI.
- g. All the data and results of testing and calibration of the entire system at manufacturer's site as well as at ARCI shall be properly documented and supplied to ARCI
- h. Certificate for general compliance with standard, safety and protection. Safety and security instruction manual should be provided

E. After-sales service:

The supplier shall guarantee efficient and prompt after-sales service including the supply of the spares for a minimum period of 10 years after the guarantee/warranty period under mutually agreed terms and conditions.

F. Bought-out items:

All bought-out sub-systems and components if any should be of reputed make conforming to international standards. Make and details of all bought-out sub-systems and components shall be specified.

G. General Quote:

The breakup for accessories, attachments, consumables, powders, sub-systems (Powder recovery systems and vacuum cleaners) and AMC apart from the basic system, should be quoted separately as optional items and to be submitted with Technical bid (Cover 2).

List of consumables for seamless operation for next 03 (three) years should be provided and the price should be quoted as optional and to be submitted with Technical Bid (Cover 2).

Rate quoted for optional items shall not be considered for deriving L1.

Bidders shall download the Schedule of Quantities and Prices in the XLS Format and save it without changing the name of the file. Bidder shall quote their rate in figures in the appropriate cells, thereafter save and upload the file in financial bid cover (Price Bid) only. Bidder shall quote the prices in the given format BOQ_XXXX in excel sheet for online submission of bids. The Technical bid also shall be uploaded in CPP Portal in the appropriate place.

It is required to take utmost care for uploading Schedule of Quantities & Prices and any change/modification of the price schedule shall render it unfit for bidding.

If the template of Schedule of Quantities & Prices file is found to be modified/ corrupted in the eventuality by the bidder, the bid will be rejected.

H. Export License:

The supplier should clearly indicate their ability/readiness to obtain the export license /clearance from the concerned authority for the supply of the unit as per the contract specifications to ARCI.

I. Technical compliance statement:

The vendor should provide item wise details against each and every specification, Deviations if any are to be highlighted with remarks. Suppliers are required to provide the Technical Compliance Statement as per Annexure – III while submitting the Technical Bid (Cover 2).

J. Guarantee/warranty:

The system must be under guarantee / warranty for a period of minimum 03 (three) years (unconditional warranty) from the date of its satisfactory installation, commissioning, and demonstration against all manufacturing defects. If the system is found to be defective during this period the whole equipment or part thereof will have to be repaired/replaced by the supplier free of cost to ARCI. During the guarantee / warranty period, the downtime of the equipment

will be recorded with the details of date and type of complaint/fault. The vendor should attend it and make the equipment operational within reasonable and stipulated time. The downtime more than the stipulated time after reporting the complaint/fault will be added to calculate cumulative downtime. The guarantee/warranty period will be extended automatically by this cumulative downtime. However, if the items are under guarantee/warranty for a period of more than three years, it may be specifically mentioned in the quotation. In case the supplier fails to rectify the defects and equipment is not put to proper function to our satisfaction, the supplier will replace the whole equipment to our satisfaction or whole money paid by ARCI on the account of purchase of the equipment will be refunded by supplier to ARCI. All the software updates during the warranty period shall be supplied, installed and trained to our personnel on real time basis at free of cost.

K. Delivery/ time schedule:

The offer shall be accompanied by a detailed delivery time schedule showing the individual time schedule required for delivery.

L. Packing:

The Supplier shall provide such packing of the Goods as is required to prevent their damage or deterioration during transit to their final destination. The packing shall be sufficient to withstand, without limitation, rough handling during transit and exposure to extreme temperatures, salt and precipitation during transit and open storage. Packing case size and weights shall take into consideration, where appropriate, the remoteness of the Goods' final destination and the absence of heavy handling facilities at all points in transit. In order to maintain safety of the equipment, we prefer to have wooden crating with adequate cushion inside for transportation of any goods. The material has to be dispatched with International standard packing to withstand rigors, and to avoid any transit damages.

M. Packing Instructions:

Each package will be marked on three sides with proper paint/indelible ink, the following:

- i. Purchaser Name & Address
- ii. Item Nomenclature
- iii. Order/Contract No.
- iv. Country of Origin of Goods
- v. Packing list reference number

N. Insurance:

The Goods supplied under the Contract shall be fully insured in Indian Rupees against loss or damage incidental to manufacture or acquisition, transportation, storage and delivery.

For delivery of goods at the purchaser's premises, the insurance shall be obtained by the Supplier in an amount equal to 110% of the value of the goods from "Warehouse to warehouse" (final destinations) on "All Risks" basis including War Risks and Strikes. The insurance shall be valid for a period of not less than 3 months after dispatch **or upto installation and commissioning of stores whichever is later.** However, in case of orders placed on FOB/FCA basis, the purchaser shall arrange insurance.

O. General instructions:

- A. The bidder should submit the scanned copy of the Technical Bid for online submission and original hard copy of all the documents must be submitted in an organized and structured manner. No brochures/leaflets etc. should be submitted in loose form. Please indicate page nos. on your quotation. The price should not be mentioned anywhere in this document.
- B. The original hard copies of Technical Bid documents along with supporting documents etc., should be submitted on or before the due date. The bidder should ensure that all the technical documents submitted through online and hard copies are one and the same. If any deviation is found, the tender is liable to be rejected.**
- C. Price Bid should be submitted online only and no other mode of submission is acceptable.**
- D. The technical offer should be complete to indicate that all products and services asked for are quoted. Each page of the bid and strikeout/corrections shall be duly signed and stamped by the bidder. Unsigned Tenders are liable to be rejected. Failure to comply with this requirement may result in the bid being rejected.
- E. The purpose of certain specific conditions is to get or procure best product/service etc. for ARCI. The opinion of Technical Committee shall be the guiding factor for technical short listing.
- F. Vendor should provide list of deliverables / bill of materials and services.

PART- 2
EARNEST MONEY DEPOSIT – TERMS AND CONDITIONS

Earnest Money Deposit (EMD) for an amount of Rs. 16,25,000/- in the form of demand draft / Banker's Cheque Drawn in favour of **Director, International Advanced Research Centre, Payable at Hyderabad** should be submitted on or before the due date as part of Technical Bid. **Scanned copy of such document must be attached online along with the technical bid documents, failing which tender document would be rejected.**

No interest is payable on EMD. The EMD will be returned to the bidders(s)/Agents whose offer is not accepted by ARCI within one month from the date of the placing of the final order(s) on the selected bidder(s). EMD of the successful bidder shall be converted into performance guarantee and shall be released on submission of bank guarantee.

EMD in the form of BG is not acceptable.

Amount of EMD: Rs. 16,25,000/- in INR (Rupees Sixteen Lakh Twenty Five Thousand in INR or equivalent foreign currency)

Bidder registered with Department of Micro, Small and Medium Enterprises as MSMEs and having valid NSIC registration are exempted for payment of EMD subject to submission of documentary evidences. Copies of registration certificate and other supporting documents should be submitted in Cover No. 1.

Documents required for availing exemption of EMD amount for NSIC/MSEs:

- a. MSMEs, which are specified by the Ministry of Micro, Small and Medium Enterprises under MSME Act 2006 and Public Procurement Policy, 2012 as Manufacturing/service Enterprises should have registered with NSIC under its Single Point Registration Scheme (SPRS).
- b. The Certificate with monetary limit indicated should be valid on the scheduled date/Extended date of submission of the tender. Certificates without monetary limit will not be considered.
- c. The items of product/services mentioned under MSME/NSIC certificate should be the same or similar to the tendered items.
- d. The monetary limit stipulated in the certificate of MSMEs/NSIC should be equal or more than the value of work in hand awarded under MSME benefits during the financial year plus estimated cost of the Tender for availing EMD exemptions.
- e. If monetary limit is less than the value of work in hand awarded under MSME/NSIC benefits during the financial year plus estimated cost of this tender, they should obtain "Competency Certificate" from NSIC for participating in this tender as well as to avail MSME benefits.

It is mandatory for the supplier to submit valid NSIC registration certificate having the duration of the validity of the certificate, so as to apply for the exemption from submitting EMD. Non-compliance of the same, bid will be disqualified.

Note- In case the bid is submitted as an Indian arm of a foreign bidder and the eligibility conditions were met through foreign company, then the EMD exemption cannot be claimed under the MSME status of Indian arm/subsidiary. Thus a bidder who solely on its own, fulfills each eligibility criteria conditions as per the tender terms and conditions and who are having MSME Status, can claim EMD exemption.

Forfeiture of EMD:

EMD of tenderer will be forfeited, if the tenderer withdraws or amends its tender or derogates from the tender in any respect within the period of validity of its tender. Further, if the successful tenderer fails to furnish the required performance security within the specified period, its EMD will be forfeited.

PART- 3
PRICE BID – TERMS AND CONDITIONS

PRICE BID SHOULD BE SUBMITTED ONLINE ONLY AND NO OTHER MODE OF SUBMISSION IS ACCEPTABLE.

Bidders shall download the Schedule of Quantities and Prices in the XLS Format and save it without changing the name of the file. Bidder shall quote their rate in figures in the appropriate cells, thereafter save and upload the file in financial bid cover (Price Bid) only. Bidder shall quote the prices in the given format BOQ_XXXX in excel sheet for online submission of bids. The Technical bid also shall be uploaded in CPP Portal in the appropriate place.

It is required to take utmost care for uploading Schedule of Quantities & Prices and any change/ modification of the price schedule shall render it unfit for bidding.

If the template of Schedule of Quantities & Prices file is found to be modified/ corrupted in the eventuality by the bidder, the bid will be rejected.

I. Terms and Conditions:

- a) Tenders with any condition, including conditional rebate, are liable to be rejected.
- b) **The Price Bid/BOQ template must not be modified/replaced by the bidder, else the bid submitted is liable to be rejected for this tender.**
- c) **The bidder should carefully read the BOQ columns and feed the price as per the price breakup asked in the BOQ. If the quoted price is not as per the price breakup given in the BOQ, the concerned price bid will be rejected.**
- d) **For Domestic bidders, the unit price of materials is basic cost. GST, packing, forwarding, freight and insurance amount if any may be provided separately as per the BOQ.**
- e) **For Foreign bidders, the unit price of the materials is Ex-Works price and packing, forwarding and freight and insurance charges if any, may be provided separately as per the BOQ.**
- f) **Unit price should include main equipment (total system) including computer hardware and software as per the specifications in scope of the work (Annexure I).**
- g) **Total price is F.O.R. ARCI, Hyderabad or CIP/CIF, Hyderabad.**
- h) Printed conditions of the vendor submitted with the tender will not be binding on ARCI.
- i) The commercial bids of only the technically qualified bidders shall be considered for further processing.
- j) Commercial Bid (prices quoted) for main equipment should not be enclosed in the technical bid envelope. If the price quote is submitted with technical bid, the tender is liable to be rejected.
- k) **Rate for optional items are to be quoted ONLY in Technical Bid (Cover 2). Rate quoted for Optional items will not be considered for deriving L1.**
- l) The Director, ARCI reserves the right to accept the offer in full or in part or reject summarily or partly thereof.

II. Tenderer to inform himself fully

The tenderer is required to carefully examine the documents enclosed and get fully aware himself as to all conditions and matters which may in any way affect the works or the cost thereof, before submitting his offer.

If the tenderer finds any discrepancies, omissions, or contradictions in the documents or is in doubt as to the true meaning of any part, he shall at once contact in writing for an interpretation/clarification from the Director, ARCI.

The tenderer shall however not be entitled to any extension of time for submission of his tender on such account, unless the Director extends the due date.

III. Payment terms:

1. For import:

An irrevocable Letter of Credit [L/C] for 100% of the order value will be established by the purchaser in favour of the supplier, through purchaser's bank in India once the following condition is met:

Receipt of order acknowledgement and acceptance of the order.

THE ACTUAL PAYMENT TO SUPPLIER WILL HOWEVER BE RELEASED IN TWO STAGES IN THE FOLLOWING MANNER:

Payment for 90% of the order value will be made upon shipment of the equipment and negotiation of the following shipping documents through L/C:

- A) Signed Commercial Invoice - Original + 5 Copies
- B) Airway Bill/Bill of lading - Original + 5 Copies.
- C) Packing List -Original + 5 Copies
- D) Certificate of conformity from the supplier that stores/equipment has been tested by the supplier and the same meet the technical specification - Original + 3 Copies.
- E) Supplier's Certificate to the effect that the contents in each package are not less than those entered in the Invoice and the Packing List - Original + 3 Copies.

Balance 10% of the order value will be released through L/C upon submission of the following documents:

- A) Commercial Invoice for 10% order value.
- B) Final Acceptance Certificate [FAC] issued by the purchaser/authorized representative in original against satisfactory installation and commissioning of the equipment at ARCI Site.
- C) Bank Guarantee Equivalent to 10% of total order value covering warranty period of the

equipment issued or counter guaranteed by an Indian Bank clearly mentioning the relation with OEM if submitted by Indian Agent.

D) If the above-mentioned performance bank guarantee is not provided, 10% of the order value (i.e. second stage payment) will be released only after the expiry of the warranty period from the date of FAC.

2. Domestic purchase:

Payment Terms

Subject to deduction of taxes at source, if any,

90% of the goods cost + 100% taxes will be paid after receipt of the goods at our site subject to inspection & acceptance of the goods/works/commissioning by ARCI authorities.

Balance 10% will be paid against submission of Performance Bank Guarantee (i.e. 10% of the total order value excluding taxes etc.) from a Nationalized /Scheduled Bank valid till the expiry of the warranty period OR after completion of warranty period from the date of successful commissioning of equipment at ARCI.

IV. Inspection Certificate (IC)

The end user will provide inspection certificate after receipt of materials based on which payment will be released.

V. Liquidated damages (LD)

As time is the essence of the contract, the work period mentioned in the Service Order should be strictly adhered to. Otherwise, LD clause will be applicable /enforced. If the supplier fails to provide the services mentioned in the order within the stipulated period, the Director, ARCI shall without prejudice to any other right or remedy available in law, levy a penalty for such delay by way of liquidated damages, at 0.5% per week of delay or part thereof, subject to a maximum of 10% of contract value. Such LD will be deducted from any amount due or which may become due to the supplier.

VI. Order acceptance

The successful bidder, on award of contract/order, must send the contract/order acceptance in writing, within 15 days of award of contract.

VII. Award of contract:

ARCI reserves the right at the time of award of Contract to increase or decrease the quantity of items specified in the Schedule of Requirements without any change in price or other terms and conditions.

IX. Corrupt or Fraudulent Practices:

ARCI requires that the bidders who wish to bid for this project have highest standards of ethics.

ARCI will reject a bid if it determines that the Bidder recommended for award has engaged in corrupt or fraudulent practices while competing for this contract. ARCI may declare a vendor ineligible, either indefinitely or for a stated duration, to be awarded a contract if it at any time it is determined that the vendor has engaged in corrupt and fraudulent practices during the execution of contract.

X. Integrity Pact:

As per directive of the Central Vigilance Commission all the government funded organizations have to adopt an Integrity pact (IP) to ensure transparency, equity and competitiveness in major Public procurement activities. The integrity pact envisages an agreement between the prospective bidders/vendors with the ARCI committing the persons/officials of both the parties i.e., ARCI and intending bidders with the aim not to exercise any corrupt practice and bring influence on any contractual aspects. Only those bidders/vendors who are willing to enter in to such an integrity pact with ARCI only have to compete in the bidding. The integrity Pact would be effective from the date of invitation of bids and continue to be in force till completion/satisfactory execution of the contract. Bidders shall submit the Integrity Pact in Technical Bid (Cover 2) as per the prescribed format given in Annexure IV.

XI. Interpretation of the clauses in the Tender Document/Contract Document:

In case of any ambiguity/dispute in the interpretation of any of the clauses in this Tender Document, Director, ARCI's interpretation of the clauses shall be final and binding on all parties.

XII. Arbitration

In case of Dispute or difference arising between the Purchaser and a domestic supplier relating to any matter arising out of or connected with this agreement, such disputes or difference shall be settled in accordance with the Indian Arbitration & Conciliation Act, 1996, the rules there under and any statutory modifications or re-enactments thereof shall apply to the arbitration proceedings. The dispute shall be referred to arbitrator appointed by the Director, ARCI. The award of the arbitrator so appointed shall be final, conclusive and binding on all parties to this order.

The venue of the arbitration shall be the place from where the purchase order/contract is issued. Notwithstanding any reference to arbitration herein, the parties shall continue to perform their respective obligations under the Contract unless they otherwise agree.

Declaration by the Vendor

(to be provided in the following format in their letter head)

It is hereby declared that I/We the undersigned, have read and examined all the terms and conditions etc. of the tender document for which I/We have signed and submitted the tender under proper authorization. It is also certified that all the terms and conditions of the tender document are fully acceptable to me/us and I/We will abide by the conditions of the tender. We have not given any printed conditions beyond the scope of this tender. It is also certified that I/We/our firm has no objection in signing the contract if the opportunity for the work against this tender is given to me/us.

Date:

Signature:

Name:

Address:

Designation:

On behalf of:

SCOPE OF WORK

Procurement, Installation and Commissioning of Electron Beam Melting Facility.

**Technical Specifications for Electron Beam Melting Additive Manufacturing Facility.
The EBM AM system should be based on Powder bed fusion technology.**

1.0 Build Chamber:

- 1.1 Maximum Build Size (W x D x H): 200 x 200 x 380 mm or more
- 1.2 Maximum Beam Power: 3000 W or more
- 1.3 Cathode Type: Tungsten filament or better
- 1.4 Minimum Beam Diameter: 250µm or lower
- 1.5 Maximum EB Translation Speed: 8000 m/s or more
- 1.6 Vacuum Technology: Pumping should be done by rotary pump followed by turbo pump
- 1.7 Vacuum Pressure
 - i. Column Pressure: 1×10^{-7} mbar or better
 - ii. Chamber Pressure: 10^{-5} mbar or better
 - iii. Build Atmosphere: 5×10^{-3} mbar or better
- 1.8 He Consumption during Build process: 1 liter/h or less
- 1.9 He Consumption during Build cool down: 75 liters/build cycle or lower
- 1.10 Maximum processing temperature (Bed Temperature): 1100°C or above
- 1.11 The system should be capable of processing all the standard materials listed below.
Process parameters, Process data and process theme for these standard materials should be provided.
Standard Build materials:
 - i. Titanium Ti6Al4V
 - ii. Titanium Ti6Al4V ELI
 - iii. Nickel Alloy 718
- 1.12 Supplier has to submit reference literatures that assure that machine is suitable and has been used for processing following materials
 - i. TiNi / TiAl
 - ii. Cobalt-Chrome, ASTM F75
 - iii. Pure Cu
 - iv. Pure W
 - v. Stainless steel
 - vi. Aluminium Alloys
- 1.13 **ARCI is planning to process C103 Niobium alloy using this machine after due training. Supplier has to assure that this machine can in principle process C103 Niobium Alloy. Literature to support the claim will be desirable.**

1.14 **ARCI is planning to develop non-standard alloys at its campus using gas atomizer. The EBM system should be able to process these alloy powders without affecting the warranty. Required training to create process data or process theme for all the non-standard alloys and C103 Niobium alloy should be provided. Any criteria to check suitability of the powder for EBM system should be included in the Bid. Any restriction on types of powder should be described with the bid.**

1.15 Build Properties for Ti-6Al-4V and IN718:

- | | |
|--|------------------------|
| a. Porosity: | 0.2% or lower |
| b. Surface Roughness: | Sa value 35µm or lower |
| c. Typical Geometrical Accuracy: | +/- 0.2mm or better |
| d. Min. Resolution in Hole diameter: | min 0.5mm or better |
| e. Min. Resolution in Feature thickness: | min 0.3mm or better |

1.16 **Quality of the build should be same at entire build area**

2.0 Powder Recovery System (TO BE QUOTED AS OPTIONAL)

Two separate Powder recovery systems for Titanium powder and IN718 powders respectively. Unmelted powder should be removed from the built components by blasting in a closed chamber. Recovered powder should be usable after sieving. The powder recovery system should have all the operational provisions mentioned above for efficient recovery of powders.

3.0 Consumable Pack enough for 3 (three) years of operation should be included as optional. Details of each item in the pack, quantity required for 3years operation, and respective price should be quoted.

4.0 Site Pack

Necessary tools and site spares for the EBM Machine.

5.0 Vacuum Cleaner (TO BE QUOTED AS OPTIONAL)

Vacuum cleaner for powder. The vacuum cleaner should be approved by certified agencies for powder safety. Two units should be quoted, one for the build chamber where the powder is to be recycled and one for waste powder outside the build chamber.

6.0 Water Cooling Chiller

Chiller unit for adequate cooling in EBM system according to the ambient condition in the Hyderabad, India.

Ambient condition in Hyderabad- Typical Temperature range: +10°C to +50°C

Humidity: 30-90% (Generally the maximum temperature and humidity does not occur simultaneously)

7.0 Provision for Tele-servicing of the machine using high speed Ethernet connection including supply of modem & accessories required for this feature will be desirable

8.0 Software:

Term Software includes slicing software, build processor and machine control & operation. Software should be able to convert files to STL, repairs errors, edits designs and prepares

them for the build platform. Modules for support generation and to create lightweight structure, lattice structure or functional surfaces should be also included. This should have the following, among others:

- a. Option for uploading/import of standard CAD files (.stp file format).
- b. There should not be any restriction on file size.
- c. Software should be able to generate sliced layers
- d. Option for user defined build strategy as well as tool path sequencing strategy
- e. Build processor to generate process theme. It should have option to change build parameters and create user defined build strategy and process theme.
- f. Generation of program and AM operation
- g. Software license without any time limit and with all the updates for at least next 3 years
- h. Software should be provided in CD/DVD/Pen drive also (As a backup in case of any failure)

9.0 Materials: (TO BE QUOTED AS OPTIONAL)

9.1 Listed materials with mentioned quantity should be supplied.

- i. Ti-6Al-4V alloy Grade 5 - 100 kg
- ii. Ti-6Al-4V ELI alloy Grade 23 - 100 kg
- iii. Inconel 718 - 100 kg

9.2 All powders should have spherical morphology and Particle Size Distribution (PSD) should be 45-106µm. Supplied material should be suitable for the EBM system as per the quality standard of the EBM system and powders should be suitable to provide build quality specified in the specifications.

9.3 Material data sheet and test report should be enclosed. Ti-6Al-4V and In718 alloy should have certification as Aerospace grade. Ti-6Al-4V ELI alloy should have certification as Biomedical grade

10.0 Safety:

10.1 Entire machine should be as per International / European safety standards (EN ISO 12100:2010 and EN60204-1) during entire operation with respect to radiation safety, powder safety and electrical safety. It should have necessary protective enclosures, all safety accessories and safety interlocks. The Supplier should comply with all Safety features and incorporate all safety for controls and operator while in operation from possible damages and injury. Automatic machine shutoff/warnings in the event of malfunctioning beyond pre-set limits.

10.2 X-ray radiation leakage should be well within limits mentioned in international safety standard table 1.0 of AWS C7.1-2004

11.0 Qualification:

11.1 Bidder has to submit EBM manufactured Ti-6Al-4V alloy (Grade 5) component in as-build condition (**Drawing attached in Annexure II. Bidders may contact manish@arci.res.in for 3D Model**). The sample must be manufactured in their own machine similar to what they are offering. The submitted sample will be used for technical qualification. Sample will be analysed for geometrical accuracies, surface roughness and Oxygen content in the build. The build quality should be equal or better than criteria mentioned in section 1.15 and described below:

- a. Porosity: 0.2% or lower
- b. Surface Roughness (in as deposited condition): 35µm or lower
- c. Geometrical Accuracy: +/- 0.2mm or better
- d. Oxygen content in the built component must be lower than 0.15%

11.2 Supplier should have supplied at least five systems of similar specifications in the last 3 years in India or worldwide and those systems should be in operation till date.

11.3 The Supplier should provide support documents to show their Customers' list (at least five of them) with contact details. Performance certificate of latest of them should also be submitted with technical bid.

12.0 Pre dispatch inspection:

12.1 ARCI selected components have to be built. The sample component must be manufactured in the same machine in presence of ARCI scientists. The generated sample will be used for technical qualification. Sample will be analyzed for geometrical accuracies, surface roughness and Oxygen content in the build. The generated samples will be bench marked against the sample supplied with the technical bid. The sample quality should be on par with the sample submitted with technical bid and criteria mentioned in section 1.15 and 11.1.

12.2 Demonstrate the operation of the system as per specification

12.3 Demonstrate functionality of all peripheral equipment as per specifications

12.4 Demonstrate quality of build in entire build area

12.5 Certificate of conformance of the machine suiting ARCI specification from your quality department need to be produced before dispatch of the machine

13.0 Installation and commissioning:

13.1 Installation and commissioning of the machine to be done by the supplier at ARCI and proving out of the machine and demonstration of all the features is to be carried out by the supplier at ARCI

13.2 The layout, pre-installation requirements and foundation drawing of the offered machine and all the peripheral equipment should be enclosed with the Technical offer (Cover 2)

14.0 Inspection:

All the activities mentioned in Pre-dispatched inspection must be repeated during commissioning.

- 14.1 ARCI selected components have to be built. The sample component must be manufactured in the same machine in presence of ARCI scientists. The generated sample will be used for technical qualification. Sample will be analyzed for geometrical accuracies, surface roughness and Oxygen content in the build. The generated samples will be bench marked against the sample supplied with the technical bid. The sample quality should be on par with the sample submitted with technical bid and criteria mentioned in section 1.15 and 11.1.
- 14.2 Demonstrate the operation of the system as per specification
- 14.3 Demonstrate functionality of all peripheral equipment as per specifications
- 14.4 Demonstrate quality of build in entire build area
- 14.5 Safety compliance
- 14.6 Demonstration of all the safety interlocks as per International safety standard

15.0 Training:

Suitable training to enable safe, efficient operation and maintenance of the machine. The training must include:

- Machine operation, system handling
- Application development with design and build rules
- Build optimizations and process knowledge.
- Detailed software training for basic and advance operations
- Preventive maintenance, detailed maintenance training for unscheduled and specialized maintenance requirements, troubleshooting etc
- Process development using non-standard powders
- Handling of post-processing equipment for powder recovery and other accessories

16. Documentation:

The following documents (Hard copy 2 sets and soft copy in CD/Flash drive/HDD) in English Language to be provided to ARCI:

- 16.1 User manual, operation manual and maintenance manual (for mechanical, electrical and electronic hardware circuits) of the entire system and sub-systems.
- 16.2 System administration and maintenance manual- shall cover detailed system configuration and administration with the help of sketches. The safety instructions, maintenance schedule, preventive maintenance schedule with possible errors and troubleshooting to be provided.
- 16.3 Standard operating procedure (SOP), calibration, software manual
- 16.4 Original software licences for all the software included in the supply
- 16.5 Calibration certificates as per international standard of all the artifacts. Reference standard used for the same shall be provided to ARCI.
- 16.6 All the data and results of testing and calibration of the entire system at manufacturer's site as well as at ARCI shall be properly documented and supplied to ARCI
- 16.7 Certificate for general compliance with standard, safety and protection

17. Guarantee/Warranty

The system must be under guarantee / warranty for a period of minimum three years (unconditional warranty) from the date of its satisfactory installation, commissioning, and demonstration against all manufacturing defects. If the system is found to be defective during this period the whole equipment or part thereof will have to be repaired/replaced by the supplier free of cost to ARCI. During the guarantee / warranty period, the downtime of the equipment will be recorded with the details of date and type of complaint/fault. The vendor should attend it and make the equipment operational within reasonable and stipulated time. The downtime more than the stipulated time after reporting the complaint/fault will be added to calculate cumulative downtime. The guarantee/warranty period will be extended automatically by this cumulative downtime. However, if the items are under guarantee/warranty for a period of more than three years, it may be specifically mentioned in the quotation. In case the supplier fails to rectify the defects and equipment is not put to proper function to our satisfaction, the supplier will replace the whole equipment to our satisfaction or whole money paid by ARCI on the account of purchase of the equipment will be refunded by supplier to ARCI. All the software updates during the warranty period shall be supplied, installed and trained to our personnel on real time basis at free of cost.

Items at point no. 2, 3, 5 and 9 to be quoted as Optional Item and the rate should ONLY be quoted in Technical Bid (Cover 2). Rate quoted for Optional items will not be considered for deriving L1.

Supply of the materials, demonstration, installation and services must be done at:

**International Advanced Research Centre for Powder Metallurgy and New Materials,
Balapur Post, Hyderabad – 500 005, Telangana, India**

ANNEXURE -II

**DRAWING FOR PROCUREMENT, INSTALLATION AND COMMISSIONING
OF ELECTRON BEAM MELTING FACILITY.**

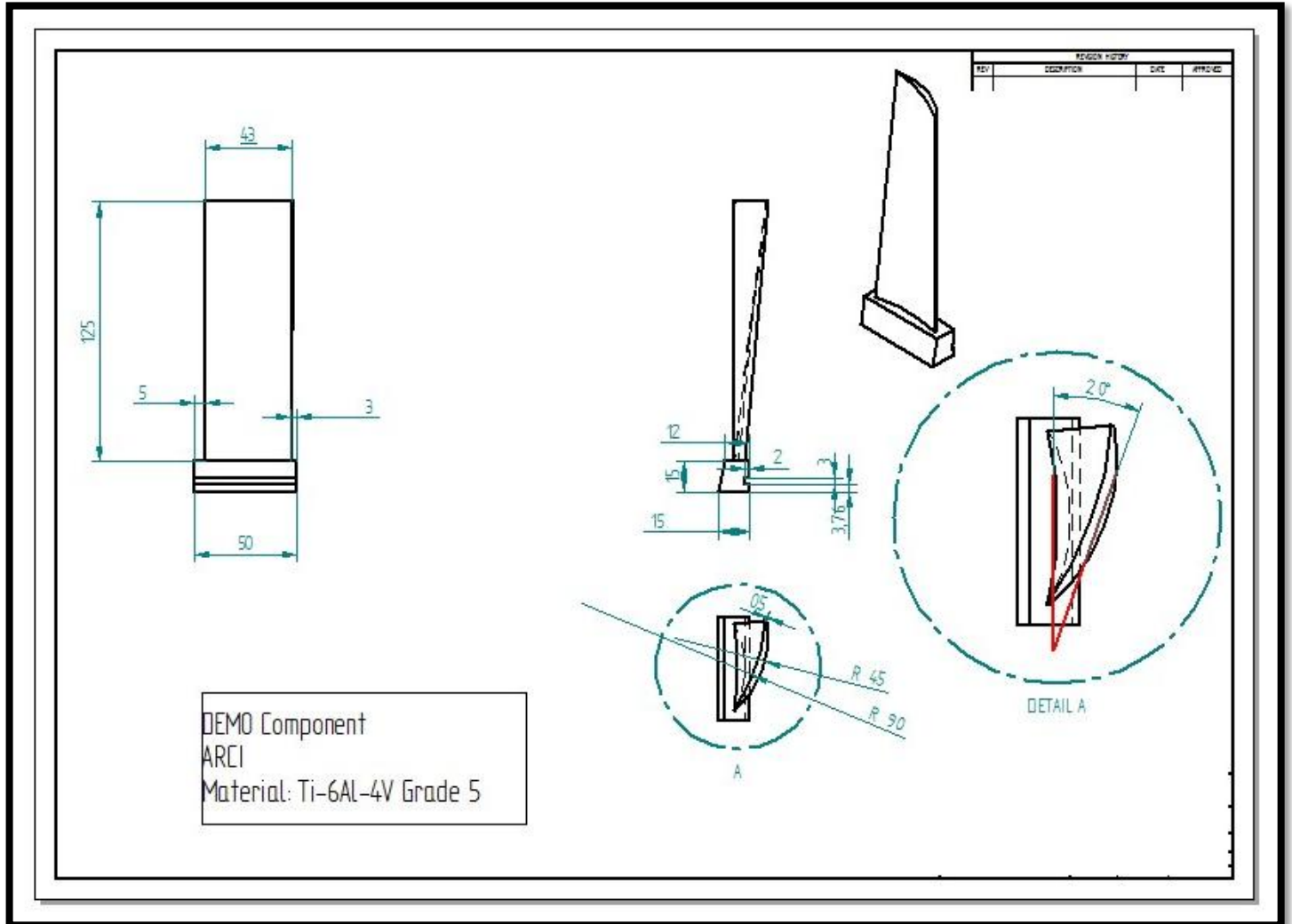

TECHNICAL COMPLIANCE STATEMENT

Procurement, Installation and Commissioning of Electron Beam Melting Facility.

Specifications	Technically compliance as per specification given (Yes/No)	Remarks (if any)
Build Chamber:		
Maximum Build Size (W x D x H): 200 x 200 x 380 mm or more \		
Maximum Beam Power: 3000 W or more		
Cathode Type: Tungsten filament or better		
Minimum Beam Diameter: 250µm or lower		
Maximum EB Translation Speed: 8000 m/s or more		
Vacuum Technology: Pumping should be done by rotary pump followed by turbo pump		
Vacuum Pressure <ul style="list-style-type: none">i. Column Pressure: 1×10^{-7} mbar or betterii. Chamber Pressure: 10^{-5} mbar or betteriii. Build Atmosphere: 5×10^{-3} mbar or better		
He Consumption during Build process: 1 liter/h or less		
He Consumption during Build cool down: 75 liters/build cycle or lower		
Maximum processing temperature (Bed Temperature): 1100°C or above		
The system should be capable of processing all the standard materials listed below. Process parameters, Process data and process theme for these standard materials should be provided. Standard Build materials: <ul style="list-style-type: none">i. Titanium Ti6Al4Vii. Titanium Ti6Al4V ELIiii. Nickel Alloy 718		
Supplier has to submit reference literatures that assure that machine is suitable and has been used for processing following materials <ul style="list-style-type: none">vii. TiNi / TiAlviii. Cobalt-Chrome, ASTM F75ix. Pure Cux. Pure Wxi. Stainless steelxii. Aluminium Alloys		
ARCI is planning to process C103 Niobium alloy using this machine after due training. Supplier has to assure that this machine can in principle		

<p>process C103 Niobium Alloy. Literature to support the claim will be desirable.</p>		
<p>ARCI is planning to develop non-standard alloys at its campus using gas atomizer. The EBM system should be able to process these alloy powders without affecting the warranty. Required training to create process data or process theme for all the non-standard alloys and C103 Niobium alloy should be provided. Any criteria to check suitability of the powder for EBM system should be included in the Bid. Any restriction on types of powder should be described with the bid.</p>		
<p>Build Properties for Ti-6Al-4V and IN718:</p> <ul style="list-style-type: none"> b. Porosity: 0.2% or lower c. Surface Roughness: Sa value 35µm or lower d. Typical Geometrical Accuracy: +/- 0.2mm or better e. Min. Resolution in Hole diameter: min 0.5mm or better f. Min. Resolution in Feature thickness: min 0.3mm or better 		
<p>1.16 Quality of the build should be same at entire build area</p>		
<p>Water Cooling Chiller</p>		
<p>Chiller unit for adequate cooling in EBM system according to the ambient condition in the Hyderabad, India. Ambient condition in Hyderabad- Typical Temperature range: +10°C to +50°C Humidity: 30-90% (Generally the maximum temperature and humidity does not occur simultaneously)</p>		
<p>Provision for Tele-servicing of the machine using high speed Ethernet connection including supply of modem & accessories required for this feature will be desirable</p>		
<p>Software</p>		
<p>Term Software includes slicing software, build processor and machine control & operation. Software should be able to convert files to STL, repairs errors, edits designs and prepares them for the build platform. Modules for support generation and to create lightweight structure, lattice structure or functional surfaces should be also included. This should have the following, among others:</p> <ul style="list-style-type: none"> a. Option for uploading/import of standard CAD files (.stp file format). b. There should not be any restriction on file size. c. Software should be able to generate sliced layers d. Option for user defined build strategy as well as tool path sequencing strategy e. Build processor to generate process theme. It should have option to change build parameters and create user defined build strategy and process theme. f. Generation of program and AM operation g. Software license without any time limit and with all the updates for at least next 3 years. 		

h. Software should be provided in CD/DVD/Pen drive also (As a backup in case of any failure).		
Safety:		
Entire machine should be as per International / European safety standards (EN ISO 12100:2010 and EN60204-1) during entire operation with respect to radiation safety, powder safety and electrical safety. It should have necessary protective enclosures, all safety accessories and safety interlocks. The Supplier should comply with all Safety features and incorporate all safety for controls and operator while in operation from possible damages and injury. Automatic machine shutoff/warnings in the event of malfunctioning beyond pre-set limits.		
X-ray radiation leakage should be well within limits mentioned in international safety standard table 1.0 of AWS C7.1-2004.		
Training:		
<p>Suitable training to enable safe, efficient operation and maintenance of the machine. The training must include:</p> <ul style="list-style-type: none"> ➤ Machine operation, system handling ➤ Application development with design and build rules ➤ Build optimizations and process knowledge. ➤ Detailed software training for basic and advance operations ➤ Preventive maintenance, detailed maintenance training for unscheduled and specialized maintenance requirements, troubleshooting etc ➤ Process development using non-standard powders ➤ Handling of post-processing equipment for powder recovery and other accessories 		
Documentation:		
The following documents (Hard copy 2 sets and soft copy in CD/Flash drive/HDD) in English Language to be provided to ARCI:		
User manual, operation manual and maintenance manual (for mechanical, electrical and electronic hardware circuits) of the entire system and sub-systems.		
System administration and maintenance manual- shall cover detailed system configuration and administration with the help of sketches. The safety instructions, maintenance schedule, preventive maintenance schedule with possible errors and troubleshooting to be provided.		
Standard operating procedure (SOP), calibration, software manual		
Original software licences for all the software included in the supply		
Calibration certificates as per international standard of all the artifacts. Reference standard used for the same shall be provided to ARCI.		
All the data and results of testing and calibration of the entire system at manufacturer's site as well as at ARCI shall be properly documented and supplied to ARCI		
Certificate for general compliance with standard, safety and protection		
Guarantee/Warranty		

<p>The system must be under guarantee / warranty for a period of minimum three years (un-conditional warranty) from the date of its satisfactory installation, commissioning, and demonstration against all manufacturing defects. If the system is found to be defective during this period the whole equipment or part thereof will have to be repaired/replaced by the supplier free of cost to ARCI. During the guarantee / warranty period, the downtime of the equipment will be recorded with the details of date and type of complaint/fault. The vendor should attend it and make the equipment operational within reasonable and stipulated time. The downtime more than the stipulated time after reporting the complaint/fault will be added to calculate cumulative downtime. The guarantee/warranty period will be extended automatically by this cumulative downtime. However, if the items are under guarantee/warranty for a period of more than three years, it may be specifically mentioned in the quotation. In case the supplier fails to rectify the defects and equipment is not put to proper function to our satisfaction, the supplier will replace the whole equipment to our satisfaction or whole money paid by ARCI on the account of purchase of the equipment will be refunded by supplier to ARCI. All the software updates during the warranty period shall be supplied, installed and trained to our personnel on real time basis at free of cost.</p>		
--	--	--

Suppliers are required to provide this Technical Compliance Statement while submitting the Technical Bid (Cover 2).

INTEGRITY PACT

Between
International Advanced Research Centre for Powder Metallurgy and New Materials hereinafter referred to as “ARCI”.

And
.....herein referred to as “The Bidder/ Contractor.”

Preamble

The ARCI intends to award, under laid down organizational procedures, contract/s for The ARCI values full compliance with all relevant laws of the land, rules, regulations, economic use of resources and of fairness/ transparency in its relations with its Bidder(s) and/or Contractor(s).

In order to achieve these goals, the ARCI will appoint an Independent External Monitor (IEM), who will monitor the tender process and the execution of the contract for compliance with the principles mentioned above

Section 1 – Commitments of the ARCI

- (1) The ARCI commits itself to take all measures necessary to prevent corruption and to observe the following principles:
 - a. No employee of the ARCI, personally or through family members, will in connection with the tender for, or the execution of a contract, demand, take a promise for or accept, for self or third person, any material or immaterial benefit which the person is not legally entitled to.
 - b. The ARCI will, during the tender process treat all Bidder(s) with equity and reason. The Principal will in particular, before and during the tender process, provide to all Bidder(s) the same information and will not provide to any Bidder(s) confidential/additional information through which the Bidder(s) could obtain an advantage in relation to the tender process or the contract execution.
 - c. The ARCI will exclude from the process all known prejudiced persons.
- (2) If the ARCI obtains information on the conduct of any of its employees which is a criminal offence under the IPC/PC Act, or if there be a substantive suspicion in this regard, the Principal will inform the Chief Vigilance Officer and in addition can initiate disciplinary action.

Section 2 – Commitments of the Bidder(s)/Contractor(s)

- (1) The Bidder(s)/Contractor(s) commit himself to take all measures necessary to prevent corruption. He commits himself to observe the following principles during his participation in the tender process and during the contract execution.

- a. The Bidder(s)/Contractor(s) will not, directly or through any other Person or firm, offer, promise or give to any of the ARCI's employees involved in the tender process or the execution of the contract or to any third person any material or other benefit which he/she is not legally entitled to, in order to obtain in exchange any advantage of any kind whatsoever during the tender process or during the execution of the contract.
 - b. The Bidder(s)/Contractor(s) will not enter with other Bidders into any Undisclosed agreement or understanding, whether formal or informal. This applies in particular to prices, specifications, Certifications, subsidiary contracts, submission or non-submission of bids or any other actions to restrict competitiveness or to introduce cartelization in the bidding process.
 - c. The Bidder(s)/Contractor(s) will not commit any offence under the relevant IPC/PC Act; further the Bidder(s)/Contractor(s) will not use improperly, for purposes of competition or personal gain, or pass on to others, any information or document provided by the ARCI as part of the business relationship, regarding plans, technical proposals and business details, including information contained or transmitted electronically.
 - d. The Bidder(s)/Contractor(s) of foreign origin shall disclose the name and address of the Agents/representatives in India, if any. Similarly the Bidder(s)//Contractors(s) of Indian Nationality shall furnish the name and address of the foreign principals, if any.
 - e. The Bidder(s)/Contractor(s) will, when presenting his bid, disclose any and all payments he has made, is committed to or intends to make to agents, brokers or any other intermediaries in connection with the award of the contract.
- (2) The Bidder(s)/Contractor(s) will not instigate third persons to commit offences outlined above or be an accessory to such offences.

Section 3 – Disqualification from tender process and exclusion from future Contracts

If the Bidder(s)/Contractor(s), before award or during execution has committed a transgression through a violation of Section 2, above or in any other form such as to put his reliability or credibility in question, the ARCI is entitled to disqualify the Bidder(s)/Contractor(s) from the tender process or take action as per the procedure.

Section 4 – Compensation for Damages

- (1) If the ARCI has disqualified the Bidder(s) from the tender process prior to the award, the ARCI is entitled to demand and recover the damages equivalent to Earnest Money Deposit.

Section 5 – Equal treatment of all Bidders / Contractors/ Subcontractors

- (1) The Bidder(s)/Contractor(s) undertake(s) to demand from all Subcontractors a commitment in conformity with this Integrity Pact, and to submit it to the ARCI before contract signing.
- (2) The ARCI will enter into agreements with identical conditions as this one with all Bidders, Contractors and Subcontractors.
- (3) The ARCI will disqualify from the tender process all bidders who do not sign this Pact or violate its provisions.

Section 6 – Other provisions

- (1) This agreement is subject to Indian Law. Place of performance and Jurisdiction is the Registered Office of the ARCI i.e. Hyderabad.
- (2) Changes and supplements as well as termination notices need to be made in writing. Side agreements have not been made.
- (3) If the Contractor is a partnership or a consortium, this agreement must be signed by all partners or consortium members.
- (4) Should one or several provisions of this agreement turn out to be invalid, the remainder of this agreement remains valid. In this case, the parties will strive to come to an agreement to their original intentions.

(For & On behalf of the ARCI)
(Office Seal)
Place.....
Date.....

(For & On behalf of Bidder/Contractor)
(Office Seal)
Place.....
Date.....

Witness 1:
(Name & Address): _____

Witness 2:
(Name & Address): _____

CHECK LIST

BIDDER HAS TO FILL IN THE CHECK LIST GIVEN BELOW

**(Following documents are to be submitted online and manual as part of Technical Bid.
Bidders are requested to state Yes / No against each column)**

Sl. No.	Description	Online Submission	Manual Submission
1.	If bidder is not an original equipment manufacturer, authorization letter attached.		
2.	Whether Earnest Money Deposit (EMD) Submitted		
3.	Whether Technical Bid Submitted		
4.	Integrity Pact		
5.	Whether Rate for Optional items are quoted in Technical Bid (Cover 2)		
6.	Whether Commercial Bid Submitted (Cover 3)		No offline submission. Only ONLINE submission.
7.	PAN / GSTIN Number from concerned authorities		
8.	Details of Products and Components		
9.	Whether declaration form signed and Submitted (Scanned Copy by online and original by manual)		
10.	Whether warranty clause mentioned		
11.	This Checklist (Scanned Copy by online and original by manual)		
12.	Whether all pages of tender document signed and uploaded		

NOTE: Please ensure all the relevant boxes are marked YES/NO against each column.

IMPORTANT NOTE: Tenderers must ensure that all the required documents indicated in the Tender documents are submitted without fail. Tenders received without supporting documents for the various requirements mentioned in the tender document are liable to be rejected at the initial stage itself.
